



" We Put The Quality In Conversions "

Visit our web site at [www.dualcurve.com](http://www.dualcurve.com)

For Alternate Fuels

## FORD IGNITION START CONTROL PN 56531

APPLICATIONS		
Years	Models	Engines w/COIL ON PLUG
1997 - 2001	F & E Series Trucks & Vans	4.6, 5.4,
1999 - 2001	Town Car, Crown Victoria	& 6.8L

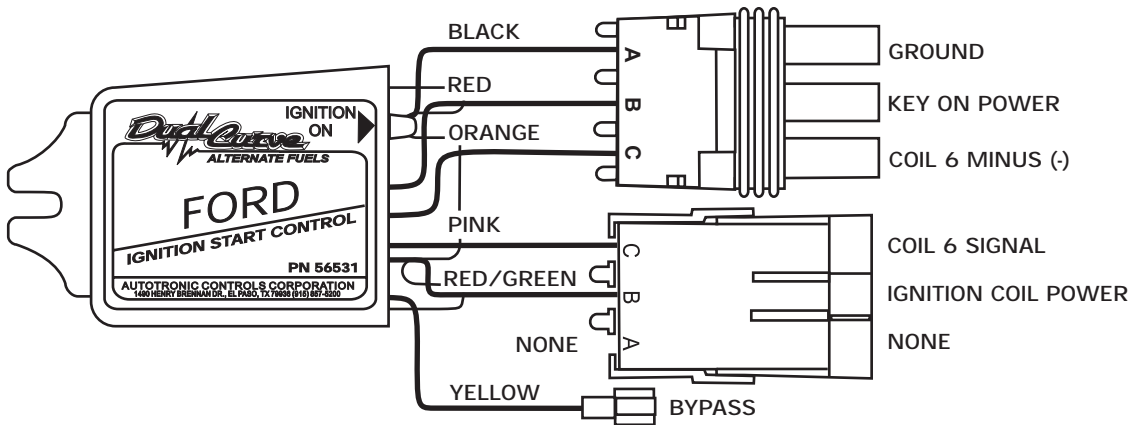

### FEATURES & THEORY OF OPERATION

#### START UP BACKFIRE PREVENTION

The Ford - Ignition Start Control's (**ISC**) will prevent start-up backfire during alternate fuel operation. The controller delays the ignition until the Ford OEM computer synchronizes with the cam sensor and generates no waste spark.

The Ford OEM computer uses crank and cam sensors signals to drive the ignition coils. The cam sensor generates a trigger every two engine-revolutions to determine which cylinders will be under compression versus exhaust. Under normal running conditions, one coil sparks while it is in a compression cycle. During the crank cycle, the OEM computer will fire two coils at the same time before the cam sensor signal is detected. One of these coils is to a cylinder in a compression cycle. The other coil is to a cylinder in an exhaust cycle, which is called a waste spark. On gaseous fuel conversions, the intake manifold and the exhaust cylinder may contain a combustible air/fuel ratio during cranking. A waste spark in the exhaust cylinder during cranking will ignite the fuel in the cylinder, and generate an intake backfire through the open intake valve.

The Dual Curve - **ISC** will delay the ignition firing until no waste spark signal is detected from the ECM. This delay may cause a slight increase in crank duration. The **ISC** eliminates the need for other backfire accessories, such as EGR purge solenoids.

Installation Instructions

PARTS INCLUDED IN THIS KIT:			
Qty.	Description	Figure	Page
1	Electronic Control Unit	5 & 6	1, 5, & 6
1	Wire Harness	2, 3, & 4	3, 4, & 6
1	Instruction Manual	N/A	N/A
1	Parts Bag Includes:	"	"
1	3/8 Ring Terminal	"	"
3	8-15x.750 Sheet Metal Screws	"	"
3	Heat-shink tubes	"	"

TOOLS REQUIRED
#28 Drill Bit (9/64 = .140)
Crimping tool
Heating device (Heat gun or small butane torch)
Phillips Screwdriver
Rosin Core Solder
Soldering Iron
Wire strippers & cutters

## PRECAUTIONARY STATEMENT

Be sure to read, understand, and follow these instructions thoroughly before starting installation. Failure to read and follow these instructions thoroughly may result in improper vehicle operation, may lead to personal injury or property damage, and may void warranty coverage. (See Warranty notice on back of instructions)

### WARNINGS



- This installation is to be done only by technicians licensed or certified to work on alternate fuel conversions.
- Always test the vehicle for proper operation on Gasoline before beginning installation.
- Always disconnect Negative (-) Battery cable before working on any wiring

## SECTION I HARDWARE INSTALLATION

### STEP 1: MOUNTING THE CONTROL

- Locate an adequate flat area on the firewall.
- Use the unit to mark the three mounting drill holes.
- Drill three holes to mount the unit with a #40 (.128") drill bit. Use the screws provided to mount the controller.
- Connect the wire harness to the unit and route the appropriate wires to the necessary components to ensure adequate wire length is available.



**CAUTION: DO NOT** mount components or wires near the exhaust manifold, or moving parts.

## SECTION II WIRING INSTALLATION



**CAUTION: DISCONNECT THE NEGATIVE(-) BATTERY CABLE BEFORE WORKING ON ANY WIRING!**

**NOTE:** ● — Indicates soldered connection with heat-shrink.

### STEP 2: WIRING CONTROLLER POWER & COIL + INTERRUPT

- Locate the 42 Pin Fuel Charge/Engine Control Harness Connector (See Fig. 1 Next page)

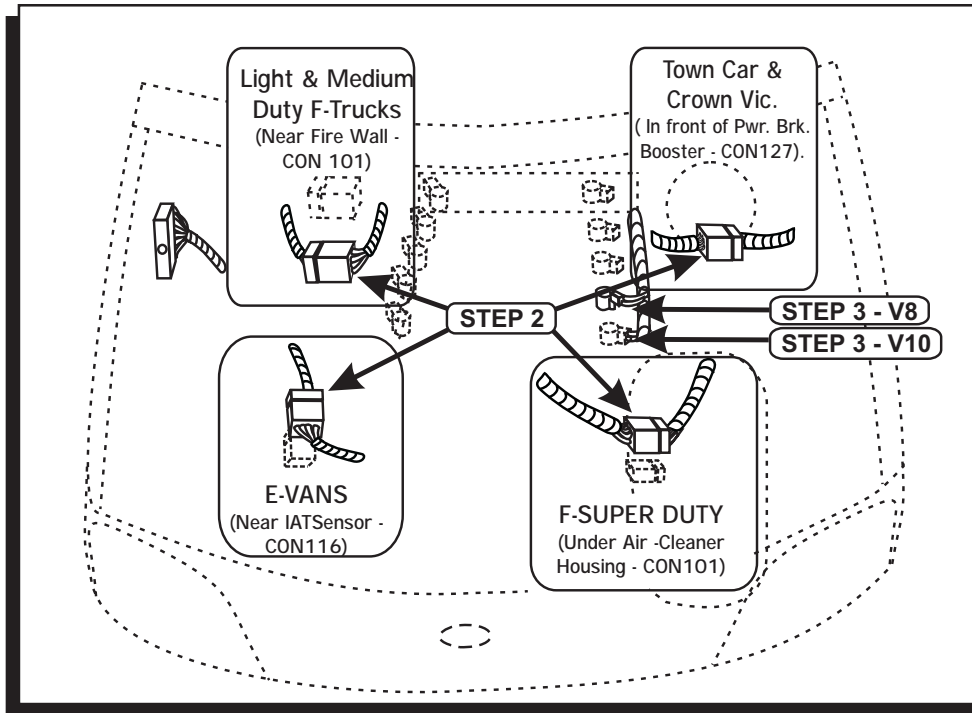

FIGURE 1 CONNECTOR & COIL LOCATIONS

**STEP 2: WIRING CONTROLLER POWER & COIL + INTERRUPT (SEE FIGURE 2)**

- B. Loosen the connector bolt until the connector separates from the mating connector.
- C. Locate the **COIL KEY-ON POWER WIRE - RED/LT GREEN** on PIN 34.
- D. Cut the **COIL KEY-ON POWER WIRE - RED/LT. GREEN** on PIN 34. .
- E. Solder the PN56531 RED wire to the harness (power) side of the cut OEM COIL POWER wire.
- F. Solder the PN56531 RED/GREEN wire to the connector (coil) side of the cut OEM COIL POWER wire.

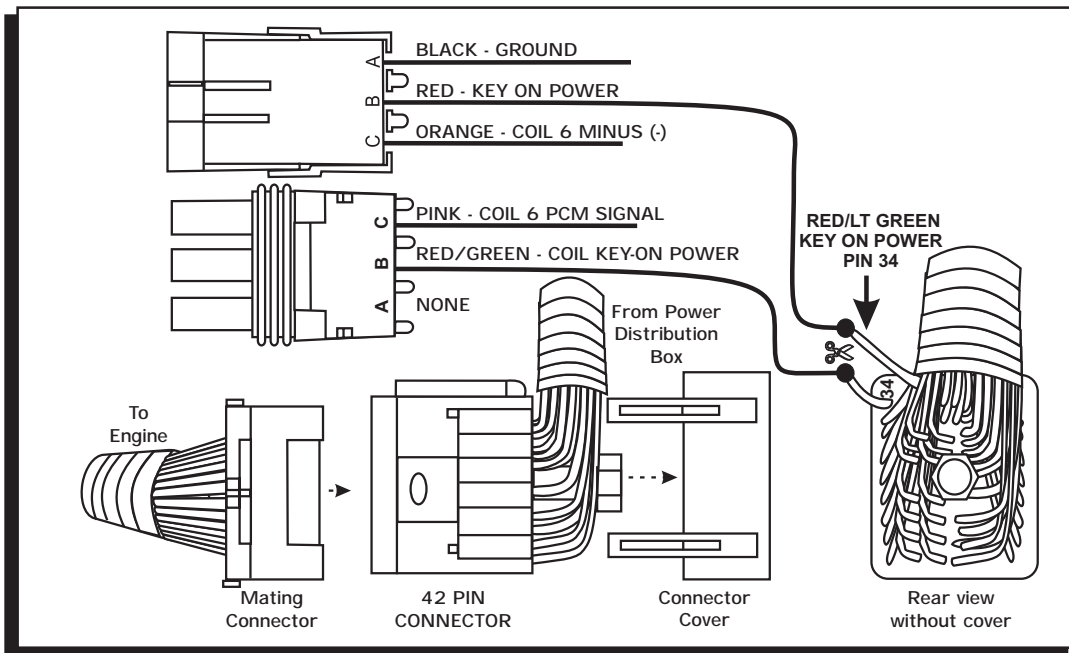

FIGURE 2 COIL POWER WIRING

## STEP 3: COIL SIGNAL INTERRUPT (SEE FIGURE 1 &amp; 3)

- A. Locate **COIL 6**.
- B. Cut the **COIL 6 SIGNAL ORG/YELLOW WIRE**.
- C. Solder the **PN56531 PINK** wire to the harness (PCM) side of the cut Coil 6 signal wire.
- D. Solder the **PN56531 ORANGE** wire to the connector (coil 6 minus) side of the cut Coil 6 signal wire.

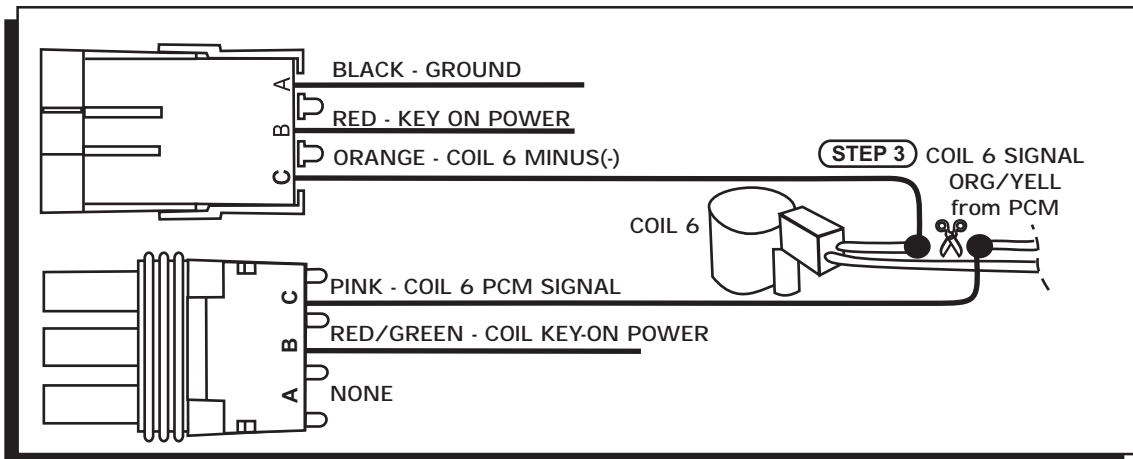

FIGURE 3 COIL SIGNAL WIRING

## STEP 4: GROUND (SEE FIGURE 4)

- A. Locate a known chassis ground strap/wire contact.
- B. Cut the **PN56531 BLACK** wire to length.
- C. Strip the **PN56531 BLACK** wire and crimp on the ring terminal provided in the parts kit.
- D. Using the OEM nut, install the **PN56531 GROUND** ring terminal on the OEM chassis ground strap/wire screw.

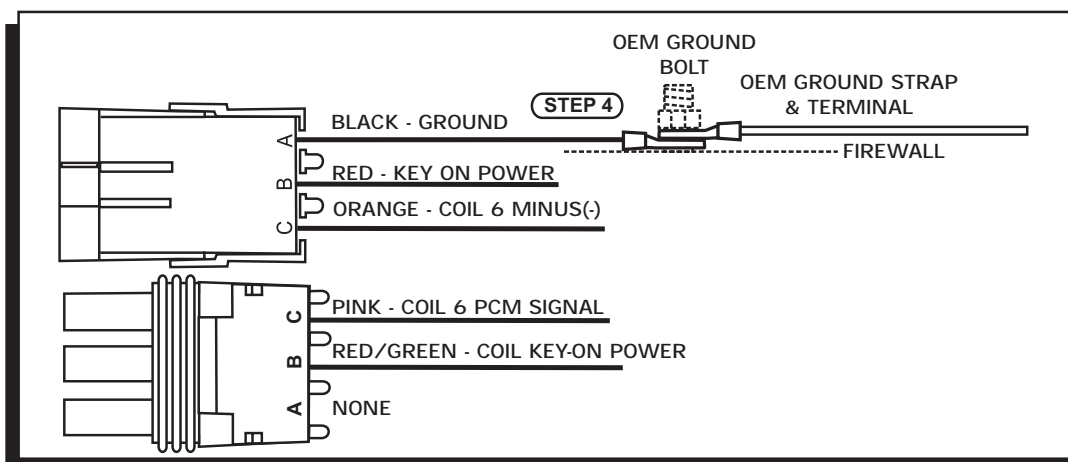

FIGURE 4 FUEL SELECT &amp; GROUND WIRING

SECTION III - OPERATIONAL TEST PROCEDURE

STEP 5: OPERATIONAL TEST

- A. Without cranking the engine, turn the **IGNITION KEY ON**.
  - 1. Observe the **PN56531 GREEN LED** is **OFF**.
- B. Using a spare jumper wire, momentarily connect the **PN56531 YELLOW** wire to **+12V**.
  - 1. Observe the **PN56531 GREEN LED** is **ON**.
  - 2. If **LED turns ON**, proceed to **STEP 5C**. If not, check **KEY ON** power, and verify continuity on jumper. (See Troubleshooting tips.)
  - 2. Disconnect the spare jumper wire from **+12V** to the **PN56531 YELLOW** wire.
- C. Start the engine.
  - 1. **LED turns ON within two seconds**.
  - 2. Verify engine starts within two seconds and runs smoothly
- D. If operating properly, installation is complete. If not, go to Troubleshooting Tips.

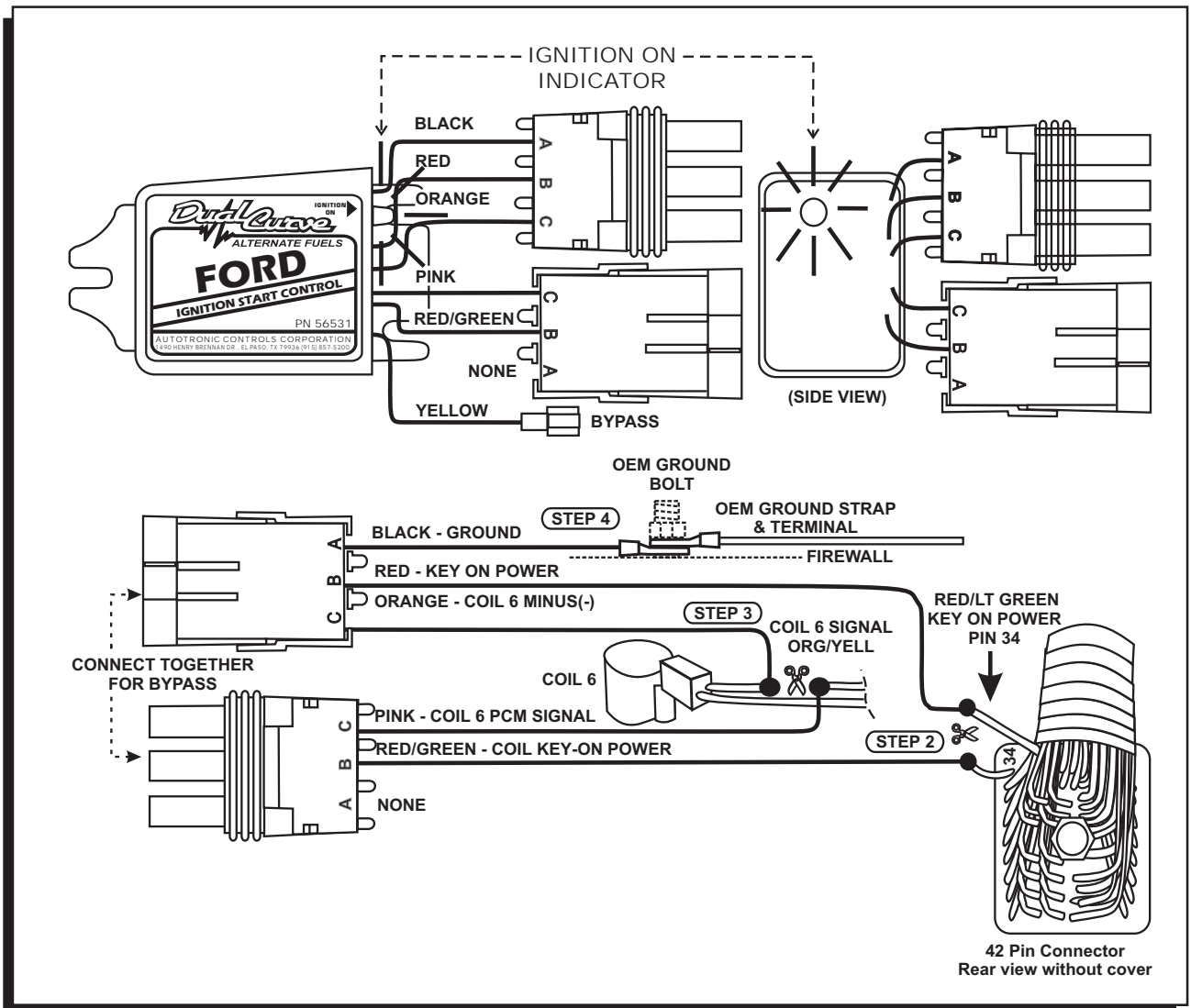

FIGURE 5 OPERATIONAL TESTING

## SECTION IV - TROUBLESHOOTING TIPS

### STEP 6: INSTALLATION INSPECTION

- Verify proper hardware installation. Verify all connections are soldered, sealed with heat-shrink, or crimped properly.
- Review "OPERATIONAL TEST & SET UP PROCEDURE."

### STEP 7: VOLTAGE TESTS

- Verify test all connections for continuity.
- Battery/KEY ON power is within OEM specs and test all connections for continuity.
- Measure voltages with a reliable volt meter and compare to "WIRING REFERENCE TABLE" for correct voltages.

 **NOTE:** All voltages reflected in the reference tables are referenced to chassis ground.

### STEP 8: ALTERNATE FUEL DELIVERY SYSTEM TEST

- Test the alternate **fuel delivery system** for proper installation and operation.

### STEP 9: DIAGNOSTIC CODES

- If MIL is on, retrieve any codes. Use a scanner with appropriate software for application.
- Review STEPS 5 to 7.

### STEP10: BYPASS CONNECTION

- Disconnect the controller from the harness.
- Connect the two connectors from the harness together.
- Switch the fuel select switch to Gasoline and test vehicle operation.



**CAUTION:** BE SURE TO PURGE ANY ALTERNATE FUEL FROM THE INTAKE BEFORE STARTING ON GASOLINE. DISCONNECT THE LOCK OFF AND CRANK THE ENGINE ON LPG BEFORE STARTING ON GASOLINE.

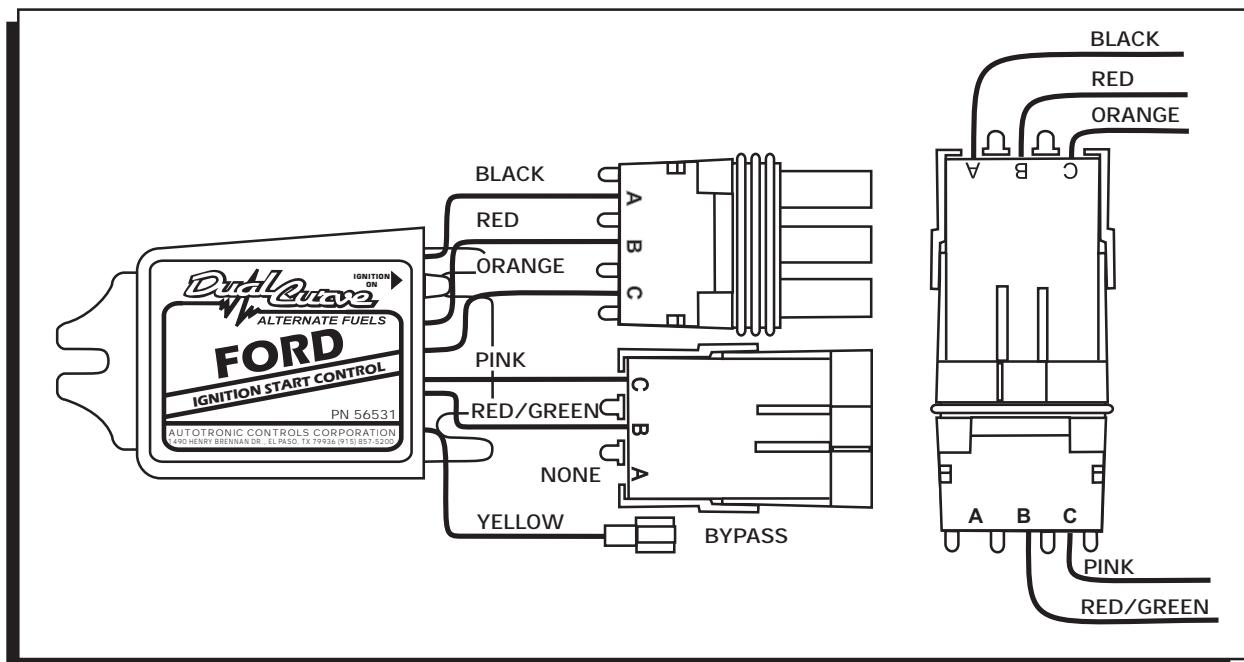

Figure 6 BYPASS CONNECTION

PN56531 WIRING REFERENCE TABLE						
PIN	WIRE COLOR	FUNCTION	CONNECTION	WIRE COLOR	VOLTAGE	CONDITION
A	BLACK	GROUND	CHASSIS OR BATT-	N/A	0.0 - 0.2	0 Ohm to Batt -
B	RED	IGNITION	42 PIN CONN PIN 34	RED/GREEN	12.0 -15.0	IGNITION ON
C	ORANGE	COIL 6 MINUS	COIL 6 MINUS (-)	ORG/YELL	13.5 - 14.1	ENG RUNNING

C	PINK	COIL 6 SIGNAL	COIL 6 HARNESS	ORG/YELL	13.5 - 14.1	ENG RUNNING
B	RED/GREEN	COIL POWER	42 PIN CONN PIN 34	REDGREEN	12.0 -15.0	IGNITION ON
A	N/A	N/A	N/A	N/A	N/A	N/A

N/A	YELLOW	ISC BY PASS	TEMPORARY KEY+12V	N/A	12.0 -15.0	ISCBYPASSONLY
-----	--------	-------------	-------------------	-----	------------	---------------

TECHNICAL FUNCTION TABLE		
WIRE/ COMPONENT	DESCRIPTION	TECHNICAL FUNCTION
YELLOW	BYPASS	Tests the LED to confirm operation. Bypasses the ISC functions by providing + 12V Power to the OEM Ignition Coils any time this wire is connected to + 12V.
RED/GREEN	IGNITION COILS (+) POWER	Provides + 12V Power to the OEM Ignition Coils as needed.
PINK	COIL 6 PCM DRIVER SIGNAL	Monitors the OEM Coil 6 driver signal from the PCM.
ORANGE	COIL 6 DRIVER SIGNAL INTERRUPT	Delays the PCM Coil 6 Driver signal when the ISC interrupts power to the Ignition Coils.
RED	KEY-ON POWER	+ 12V power source for the ISC whenever the ignition key is on.
BLACK	GROUND	Provides ground reference for the ISC from a reliable chassis ground contact.
LED	IGNITION ON INDICATOR	Indicates when power is applied to the ignition coils. (Power is applied within two seconds of cranking.)

BEFORE CALLING FOR SUPPORT CHECK...		
SYMPTOM	POSSIBLE CAUSE	ACTION
ENGINE WILL NOT START	RED and RED/GREEN WIRES, or PINK and ORANGE wires are connected in opposite directions.	Repair wiring

For technical support contact Dual Curve - Alternate Fuels at the numbers below.  
Please have the following information available.

Name: \_\_\_\_\_ Company: \_\_\_\_\_  
 City: \_\_\_\_\_ State: \_\_\_\_\_ Country: \_\_\_\_\_  
 Telephone: ( \_\_\_\_ ) \_\_\_\_-\_\_\_\_-\_\_\_\_ Fax: ( \_\_\_\_ ) \_\_\_\_-\_\_\_\_-\_\_\_\_  
 Email: \_\_\_\_\_  
 Vehicle Year: \_\_\_\_\_ Make: \_\_\_\_\_ Model: \_\_\_\_\_ Engine Size: \_\_\_\_LITRE.  
 DUAL CURVE COMPONENT PART NUMBER(S): \_\_\_\_\_  
 Symptoms & diagnostic codes : \_\_\_\_\_  
 Type of fuel: LPG  CNG  Other  Dual Fuel  Dedicated

